

WALL AND CORNER HOUSINGS - CN90



DESCRIPTION

The CN90 is an indoor corner-mount housing made from high impact ABS plastic. Designed for fixed, solid-state cameras, the unit is available with either a clear or tinted window. It also features tamper resistant fasteners.

FEATURES

- Constructed from rugged high-impact plastic
- Viewing window available in clear or tinted acrylic
- Tinted model has approximately 1 F-stop light reduction
- Clear window models work well with color cameras
- Easy to install
- Tamper resistant using captive security fasteners (special tool included)
- Ideal for installing in elevators, stairwells, lobbies, and mantraps

ARCHITECTURAL/ENGINEERING SPECIFICATIONS

The CN90 housing shall accept a solid state camera and lens for corner-mount applications, maximum camera/lens length 9.5". The housing shall be formed from high impact .187" thick, beige, textured ABS plastic. The camera viewing window shall be manufactured from .125" thick acrylic in all models, and shall be available clear or tinted (1 F-stop light reduction). Tamper resistant security fasteners, with installation tool, shall be included.

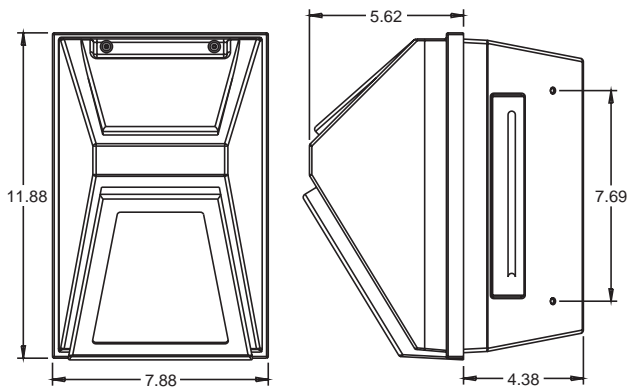

MODELS

CN90C - Corner mount, beige, high impact plastic housing with clear viewing window and tamper resistant fasteners (special tool included).

CN90T - CN90C with tinted viewing window (1 F-stop light reduction).

SHIPPING SPECIFICATIONS

Model	Unit Weight	Shipping Weight	Shipping Box Dim.
CN90	5 lbs	5 Grd/12 Air	16 x 11 x 13

* Shipping weights depend on box dimensions.