

PRODUCT INSTRUCTIONS

	Specification Number	Catalog Section
INSTRUCTIONS	5189	1d
MODEL: Indoor Wall and Corner Housings ACN90		

STANDARD INSTALLATION PROCEDURE

INCLUDES MODELS: ACN90; ACN90-5A

NOTE: Mounting hardware for housing is not supplied.

- Carefully remove all equipment from the box.
- Using the Security Tool (C) provided, loosen the (2) 10-32 x 1/2" Security Screws (G) at the top of the ACN90 housing front (A) (Figure 1). The screws are captive, so they will not fully release. Open the housing front completely (Figure 2).
- Loosen the tilt knob (E) on the left side of the bracket mount (F) and remove the tilt mount (D) (Figure 3).
- If you are not using the center cable access hole, carefully remove either the right or left knock-out found on the ACN90 housing back (B) (Figure 4) using a utility knife.
- Place the open housing in a corner at the desired height. Mark the location of the four mounting holes and the cable access hole (Figure 5).
- Feed the cable through the access hole and place the housing at the marked location. Using appropriate hardware, mount the housing to a sturdy corner (Figure 6).
- To attach a camera with a maximum camera length of six (6) inches:
 - If the camera is to be placed from a level viewing angle to a 30° viewing angle, use a 1/4-20 screw (I) in the front hole of the tilt mount (Figure 7).
 - If the camera is to be placed from a 30° viewing angle to a 55° viewing angle, use a 1/4-20 screw (I) in the back hole of the tilt mount (Figure 8).

Attach the camera to the appropriate screw for your application, and tighten.

NOTE: VideoKit™ products are supplied with an alternate mounting bracket, as shown in Figure 10.

- Complete all electrical connections with the camera.
- Place the camera and tilt mount on the bracket mount and replace the tilt knob, but do not fully tighten (Figure 9). Adjust the camera to the desired viewing angle, but be sure the housing front and window are not touching the camera. A right angle BNC connector is included to allow extra space if needed. Tighten all connections.
- Close the housing front and tighten the (2) Security screws.

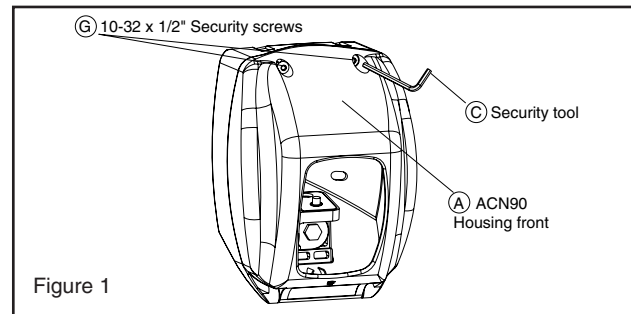

Figure 1

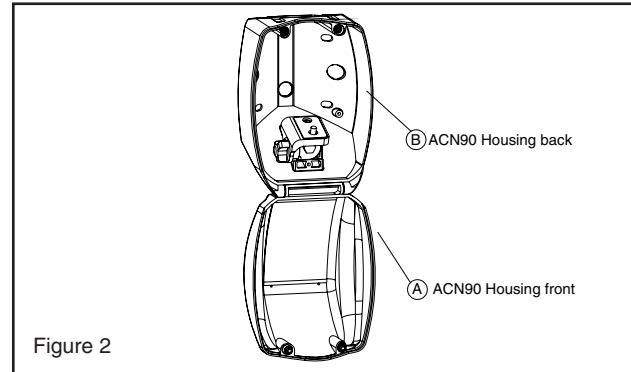

Figure 2

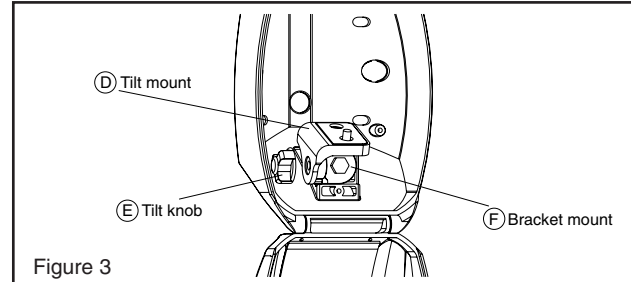

Figure 3

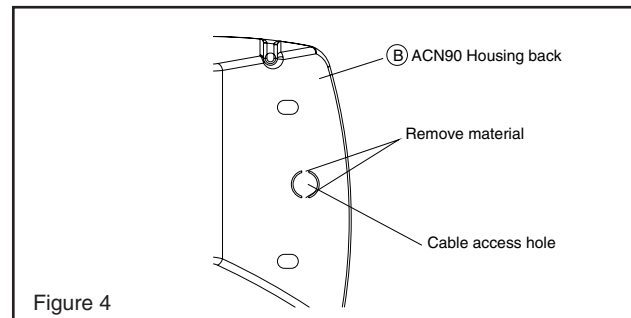

Figure 4

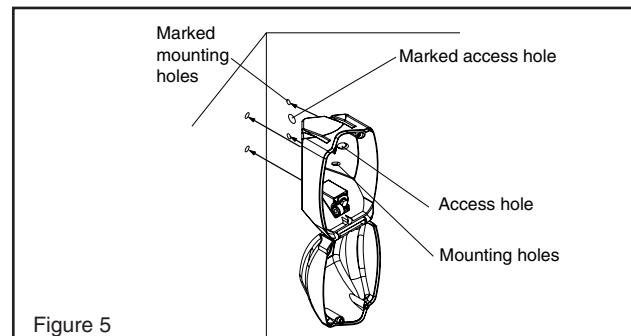

Figure 5

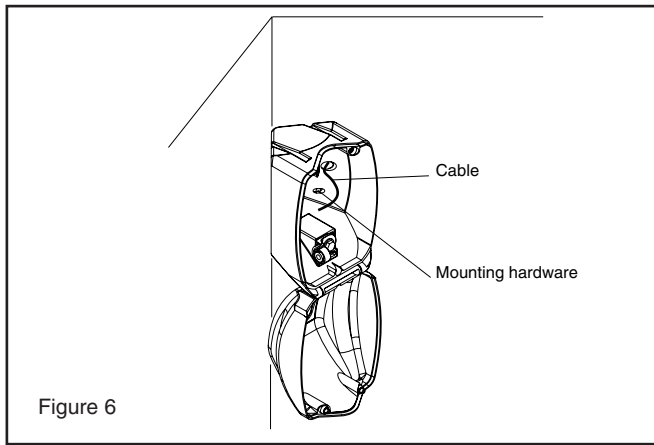

Figure 6

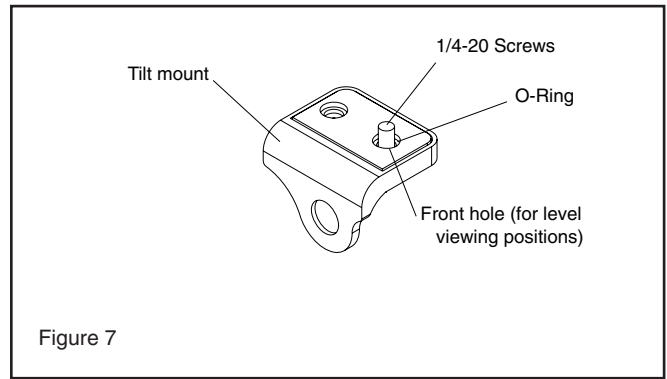

Figure 7

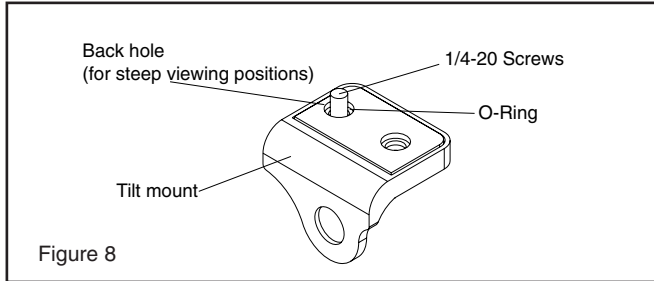

Figure 8

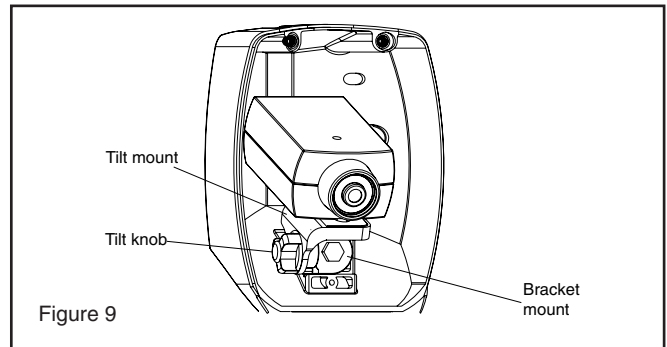

Figure 9

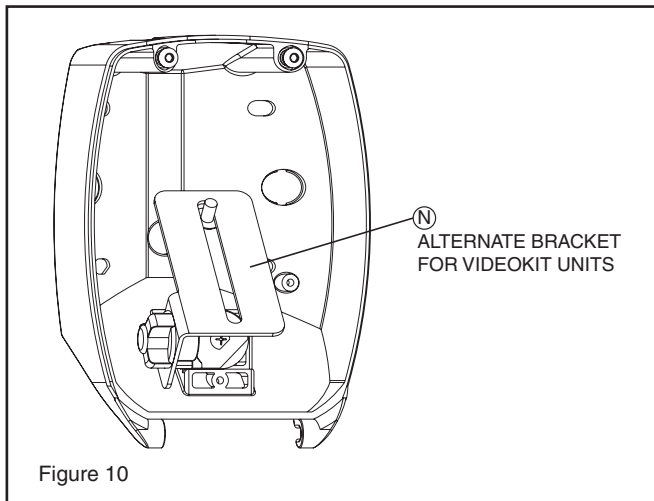
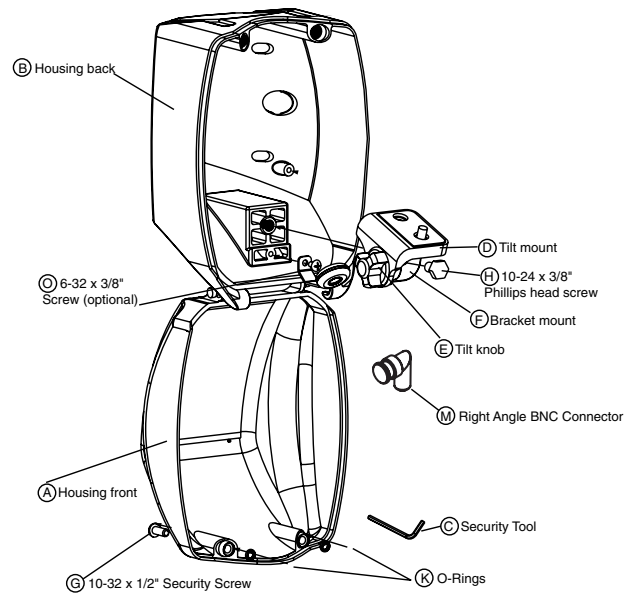

Figure 10



DESCRIPTION	Part number	Qty.
A ACN90 Housing Front	50-ACN90C	1
B ACN90 Housing Back	"	1
C Security Tool	95-fstd03	1
D Tilt Mount	50-ACN90C	1
E Tilt Knob	"	1
F Bracket Mount	"	1
G 10-32 x 1/2" Security Screws	"	2
H 10-24 x 3/8" Phillips head screw	"	2
I 1/4-20 x 3/8" Screw	"	1
J 1/4-20 O-Ring	"	1
K 10-32 O-Ring	"	2
M Right Angle BNC Connector	70-WPRA01	1
N Alternate Camera Bracket	30-VL1849	1

IMPORTANT SAFEGUARDS

1. **Read Instructions** - All the safety and operating instructions should be read before the unit is operated.
2. **Retain Instructions** - The safety and operating instructions should be retained for future reference.
3. **Heed Warnings** - All warnings on the unit and in the operating instructions should be adhered to.
4. **Follow Instructions** - All operating & user instructions should be followed.
5. **Electrical Connections** - Only a qualified electrician should make electrical connections.
6. **Attachments** - Do not use attachments not recommended by the product manufacturer as they may cause hazards.
7. **Cable Runs** - All cable runs must be within permissible distance.
8. **Mounting** - This unit must be properly and securely mounted to a supporting structure capable of sustaining the weight of the unit. Accordingly:
 - a. Installation should be made by a qualified installer.
 - b. Installation should be in compliance with local codes.
 - c. Care should be exercised to select suitable hardware to install the unit, taking into account both the composition of the mounting surface and the weight of the unit. Be sure to periodically examine the unit and the supporting structure to make sure that the integrity of the installation is intact. Failure to comply with the foregoing could result in the unit separating from the support structure and falling, with resultant damages or injury to anyone or anything struck by the falling unit.

UNPACKING

Unpack carefully. Electronic components can be damaged if improperly handled or dropped. If an item appears to have been damaged in shipment, replace it properly in its carton and notify the shipper. **Be sure to save:**

1. The shipping carton and packaging material. They are the safest material in which to make future shipments of the equipment.
2. These Installation and Operating Instructions.

LIMITED WARRANTY FOR VIDEOLARM INC. PRODUCTS

VIDEOLARM INC. warrants this Product to be free from defects in material or workmanship, as follows:

PRODUCT CATEGORY	PARTS	LABOR
All Enclosures and Electronics	Three (3) Years	Three (3) Years
Pan/Tilts	Three (3) Years **6 months if used in autoscan	Three (3) Years **6 months if used in autoscan
Poles/PoleEvators	Three (3) Years	Three (3) Years
Warrior/Q-View/I.R. Illuminators	Five (5) Years	Five (5) Years
Controllers	Three (3) Years	Three (3) Years
Power Supplies	Three (3) Years	Three (3) Years
Accessory Brackets	Three (3) Years	Three (3) Years

During the labor warranty period, to repair the Product, Purchaser will either return the defective product, freight prepaid, or deliver it to Videolarm Inc. Decatur GA. The Product to be repaired is to be returned in either its original carton or a similar package affording an equal degree of protection with a RMA # (Return Materials Authorization number) displayed on the outer box or packing slip. To obtain a RMA# you must contact our Technical Support Team at 800.554.1124, extension 101. Videolarm will return the repaired Product freight prepaid to Purchaser. Videolarm is not obligated to provide Purchaser with a substitute unit during the warranty period or at any time. After the applicable warranty period, Purchaser must pay all labor and/or parts charges.

The limited warranty stated in these product instructions is subject to all of the following terms and conditions:

1. NOTIFICATION OF CLAIMS: WARRANTY SERVICE: If Purchaser believes that the Product is defective in material or workmanship, then written notice with an explanation of the claim shall be given promptly by Purchaser to Videolarm but all claims for warranty service must be made within the warranty period. If after investigation Videolarm determines that the reported problem was not covered by the warranty, Purchaser shall pay Videolarm for the cost of investigating the problem at its then prevailing per incident billable rate. No repair or replacement of any Product or part thereof shall extend the warranty period as to the entire Product. The specific warranty on the repaired part only shall be in effect for a period of ninety (90) days following the repair or replacement of that part or the remaining period of the Product parts warranty, whichever is greater.

2. EXCLUSIVE REMEDY: ACCEPTANCE: Purchaser's exclusive remedy and Videolarm's sole obligation is to supply (or pay for) all labor necessary to repair any Product found to be defective within the warranty period and to supply, at no extra charge, new or rebuilt replacements for defective parts.

3. EXCEPTIONS TO LIMITED WARRANTY: Videolarm shall have no liability or obligation to Purchaser with respect to any Product requiring service during the warranty period which is subjected to any of the following: abuse, improper use: negligence, accident, lightning damage or other acts of God (i.e., hurricanes, earthquakes), modification, failure of the end-user to follow the directions outlined in the product instructions, failure of the end-user to follow the maintenance procedures recommended by the International Security Industry Organization, written in product instructions, or recommended in the service manual for the Product. Furthermore, Videolarm shall have no liability where a schedule is specified for regular replacement or maintenance or cleaning of certain parts (based on usage) and the end-user has failed to follow such schedule; attempted repair by non-qualified personnel; operation of the Product outside of the published environmental and electrical parameters, or if such Product's original identification (trademark, serial number) markings have been defaced, altered, or removed. Videolarm excludes from warranty coverage Products sold AS IS and/or WITH ALL FAULTS and excludes used Products which have not been sold by Videolarm to the Purchaser. All software and accompanying documentation furnished with, or as part of the Product is furnished "AS IS" (i.e., without any warranty of any kind), except where expressly provided otherwise in any documentation or license agreement furnished with the Product.

4. PROOF OF PURCHASE: The Purchaser's dated bill of sale must be retained as evidence of the date of purchase and to establish warranty eligibility.

DISCLAIMER OF WARRANTY EXCEPT FOR THE FOREGOING WARRANTIES, VIDEOLARM HEREBY DISCLAIMS AND EXCLUDES ALL OTHER WARRANTIES, EXPRESS OR IMPLIED, INCLUDING, BUT NOT LIMITED TO ANY AND/OR ALL IMPLIED WARRANTIES OF MERCHANTABILITY, FITNESS FOR A PARTICULAR PURPOSE AND/OR ANY WARRANTY WITH REGARD TO ANY CLAIM OF INFRINGEMENT THAT MAY BE PROVIDED IN SECTION 2-312(3) OF THE UNIFORM COMMERCIAL CODE AND/OR IN ANY OTHER COMPARABLE STATE STATUTE. VIDEOLARM HEREBY DISCLAIMS ANY REPRESENTATIONS OR WARRANTY THAT THE PRODUCT IS COMPATIBLE WITH ANY COMBINATION OF NON-VIDEOLARM PRODUCTS OR NON-VIDEOLARM RECOMMENDED PRODUCTS PURCHASER CHOOSES TO CONNECT TO PRODUCT.

LIMITATION OF LIABILITY THE LIABILITY OF VIDEOLARM, IF ANY, AND PURCHASER'S SOLE AND EXCLUSIVE REMEDY FOR DAMAGES FOR ANY CLAIM OF ANY KIND WHATSOEVER, REGARDLESS OF THE LEGAL THEORY AND WHETHER ARISING IN TORT OR CONTRACT, SHALL NOT BE GREATER THAN THE ACTUAL PURCHASE PRICE OF THE PRODUCT WITH RESPECT TO WHICH SUCH CLAIM IS MADE. IN NO EVENT SHALL VIDEOLARM BE LIABLE TO PURCHASER FOR ANY SPECIAL, INDIRECT, INCIDENTAL, OR CONSEQUENTIAL DAMAGES OF ANY KIND INCLUDING, BUT NOT LIMITED TO, COMPENSATION, REIMBURSEMENT OR DAMAGES ON ACCOUNT OF THE LOSS OF PRESENT OR PROSPECTIVE PROFITS OR FOR ANY OTHER REASON WHATSOEVER.

SAFETY PRECAUTIONS

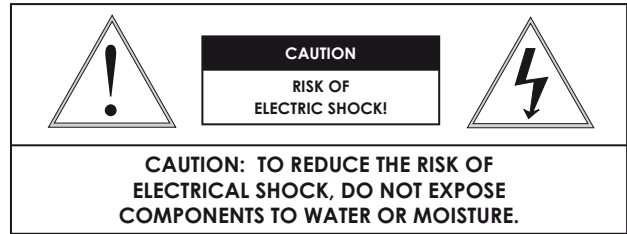

The lightning flash with an arrowhead symbol, within an equilateral triangle, is intended to alert the user to the presence of non-insulated "dangerous voltage" within the product's enclosure that may be of sufficient magnitude to constitute a risk of electric shock to persons.



The exclamation point within an equilateral triangle is intended to alert the user to presence of important operating and maintenance (servicing) instructions in the literature accompanying the appliance.

SERVICE

If the unit ever needs repair service, customer should contact Videolarm (1-800-554-1124) for return authorization & shipping instructions.

TECHNICAL SUPPORT

Videolarm has set-up a 24 hour technical support line for their customers.

24 HOUR TECHNICAL SUPPORT

1-800-554-1124